

WESTERN

WP

"They Get the Details Right"

PACIFIC



*Carpenter's
Moulding
Guide*

O R E G O N

503 • 223 • 8818

GoWestPac.com



"They Get the Details Right"

For over 30 years, the local ownership of Western Pacific has been supplying the building industry with quality products for new home construction.

As an environmentally and socially conscious company, we source the majority of our windows, doors and mouldings from regionally owned and operated manufacturers in the Pacific Northwest.

Our mission is to supply quality products on time to meet evolving homebuilders' requirements. We thank you for your business and invite your comments at GoWestPac.com.

Locations and contact information is on the back cover. Or scan this QR code to go directly to our website:

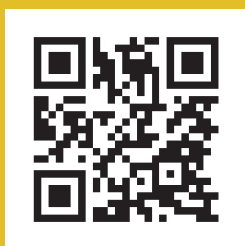



JOB SITE TAKEOFF

Our experienced, professional outside sales team will walk your jobsite and do a detailed takeoff, including as needed: prehung doors, millwork, stairparts, locks & hardware, and windows.



PREHUNG DOORS

Your dedicated WestPac team will machine and assemble our quality doors together with jambs, brickmould, weatherseals, and other components into a ready-to-install unit, with great care and quality in mind.



CUSTOM DOORS

If you're aiming for unique interior design, or exclusive entry doors, we have experts on hand who will transform your creative vision into reality.



CUSTOM MILLWORK

Whether it's beautiful arch surrounds and casing, custom run moulding patterns, or exotic wood species, we have you covered with WestPac's experienced custom millwork shop.



HAND PULLED MOULDING PACKS

We take pride in our vast assortment of casing, base, crown, and closet material, and we'll handle with care as we package your items in the quantities and lengths you need.



JOB SITE DELIVERY

We deliver, rain or shine, on time to your jobsite. Our drivers like you! They aim to please by getting out to your site quickly, and providing amazing service you can build on.



MOBILE APP

We like to give you as much information as possible on your orders. Our new mobile app provides updates on your order status, including job site photos, and details on your upcoming WestPac deliveries.

INTERIOR DOORS

MOULDING

FLAT STOCK

STAIR PARTS

HARDWARE

TECHNICAL INFORMATION

NOTES

ROUGH OPENINGS



LEFT HAND SWING

INTERIOR SINGLE DOORS

DOOR SIZE	OPENING SIZE
2'-0"	26"X82"
2'-4"	30"X82"
2'-6"	32"X82"
2'-8"	34"X82"
3'-0"	38"X82"



RIGHT HAND SWING

INTERIOR

ASTRAGAL PAIRS

DOOR SIZE	OPENING SIZE
2'-0"	50-1/2"X82"
2'-4"	58-1/2"X82"
2'-6"	62-1/2"X82"
2'-8"	66-1/2"X82"
3'-0"	74-1/2"X82"

BALL CATCH PAIRS

DOOR SIZE	OPENING SIZE
2'-0"	50"X82"
2'-4"	58"X82"
2'-6"	62"X82"
2'-8"	66"X82"
3'-0"	74"X82"

INTERIOR

BIFOLDS

DRYWALL JAMB:
(DOOR WIDTH + 1-1/4")

WOOD FULL JAMB:
(DOOR WIDTH + 2")

BIPASS DOOR

DRYWALL JAMB:
(DOOR WIDTH X 2)

WOOD FULL JAMB
(DOOR WIDTH X 2) + 1"

POCKET DOOR

WOOD FRAME
(DOOR WIDTH X 2) + 2"
(DOOR HEIGHT) + 4"
EXAMPLE: 2668 = 62" X 84"

JOHNSON FRAME
(DOOR WIDTH X 2) + 1"
(DOOR HEIGHT) + 4-1/2"
EXAMPLE: 2668 = 61" X 84-1/2"

EXTERIOR

EXTERIOR SINGLE DOORS

	6/8	7/0	8/0
2' 6"	32" X 82"	32" X 87"	32" X 99"
2' 8"	34" X 82"	34" X 87"	34" X 99"
2' 10"	36" X 82"	36" X 87"	36" X 99"
3' 0"	38" X 82"	38" X 87"	38" X 99"

12" TRANSOMS OVER 6'8" DOORS
ARE NORMALLY 94-1/2" HEIGHT

EXTERIOR SIDELITE UNIT

ONE SIDELITE, ONE DOOR
(DOOR WIDTH) + (S/L WIDTH) + 3-1/2"

TWO SIDELITES, ONE DOOR
(DOOR WIDTH) + (S/L WIDTH X 2) + 5"

TWO SIDELITES, TWO DOORS
(DOOR WIDTH X 2) + (S/L WIDTH X 2) + 6"

6' 8" HEIGHT: 82"

7' 0" HEIGHT: 87"

8' 0" HEIGHT: 99"

EXTERIOR PAIRS

(DOOR WIDTH X 2) + 3"

6' 8" HEIGHT: 82"

7' 0" HEIGHT: 87"

8' 0" HEIGHT: 99"

BASIC MOULDING TERMINOLOGY

MOULDING

FLAT STOCK

INTERIOR DOORS

STAIR PARTS

HARDWARE

TECHNICAL INFORMATION

NOTES

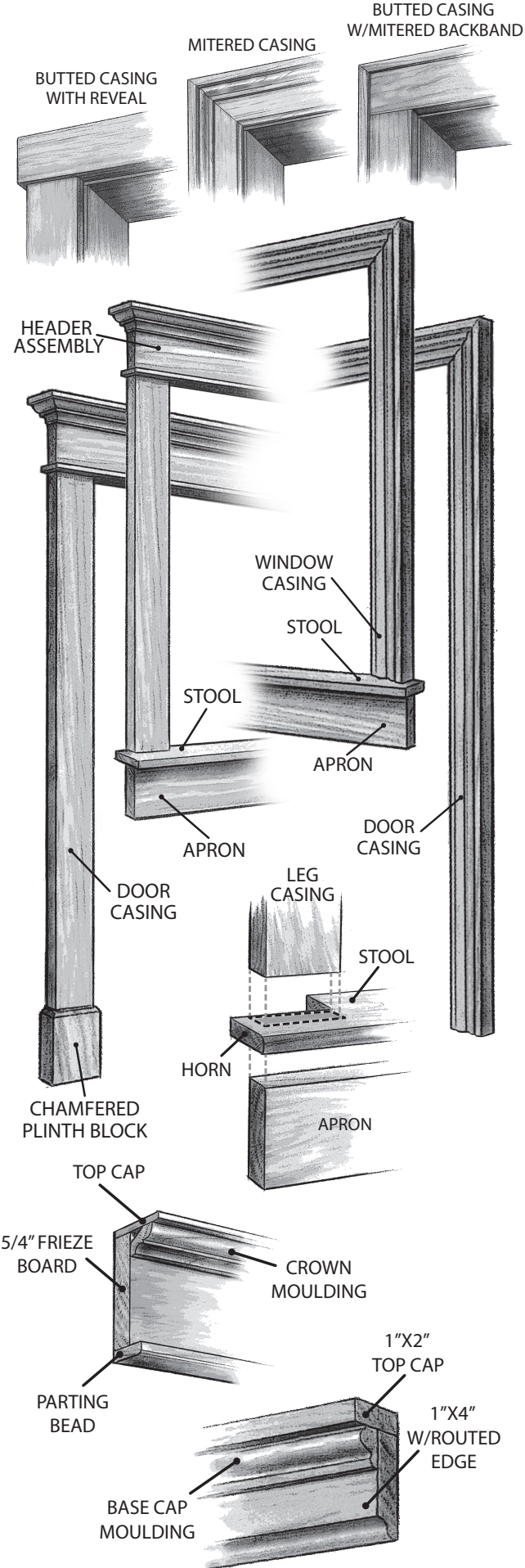

Moulding dimensions subject to change without notice, contact your local WestPac office for correct dimensions



CASING
1" X 3-1/2"



CASING
11/16" X 3-1/2"



CASING
5/8" X 2-1/4"



CASING
1-1/16" X 5-1/4"



CASING
1" X 3-1/2"

Moulding dimensions subject to change without notice, contact your local WestPac office for correct dimensions



WP154

MDF

CLASSIC CASING
13/16" X 4-1/4"



WP145

MDF
FJ
HEM

CLASSIC CASING
5/8" X 2-1/4"



WP150

MDF
FJ
HEM

CLASSIC CASING
5/8" X 3-1/4"



WP152

MDF

MODERN CLASSIC
CASING
9/16" X 3-1/2"



WP155

MDF

MODERN CLASSIC
CASING
3/4" X 4-1/4"

Moulding dimensions subject to change without notice, contact your local WestPac office for correct dimensions



WP114

BULLNOSE CASING
11/16" X 3-1/4"

MDF



WP176

CASING
Economy
7/16" X 3-1/2"

ALD
MDF



WP174

CASING
Economy
7/16" X 2-1/4"

MDF



WP175

BULLNOSE CASING
9/16" X 2-1/4"

HEM
MDF



WP100

BULLNOSE CASING
7/16" X 1-1/2"

HEM
MDF

Moulding dimensions subject to change without notice, contact your local WestPac office for correct dimensions



COLONIAL CASING
HEM • 9/16" X 2-1/8"
FJ • 5/8" X 2-1/4"



COLONIAL CASING
5/8" X 3-7/16"



TRADITIONAL
CASING
HEM • 7/8" X 3-1/4"
MDF • 13/16" X 3-1/4"

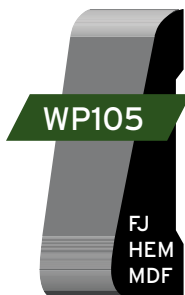

SANITARY
1/2" X 1-1/2"



TRADITIONAL
CASING
9/16" X 2-1/4"

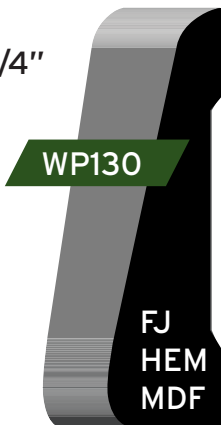

SANITARY
9/16" X 2-3/16"

Moulding dimensions subject to change without notice, contact your local WestPac office for correct dimensions

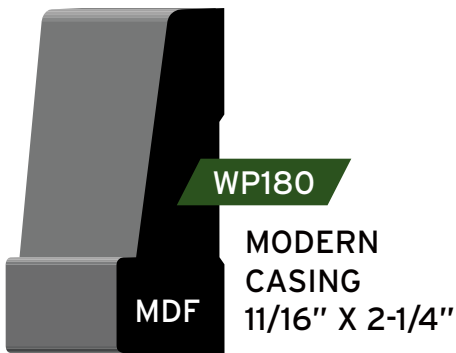
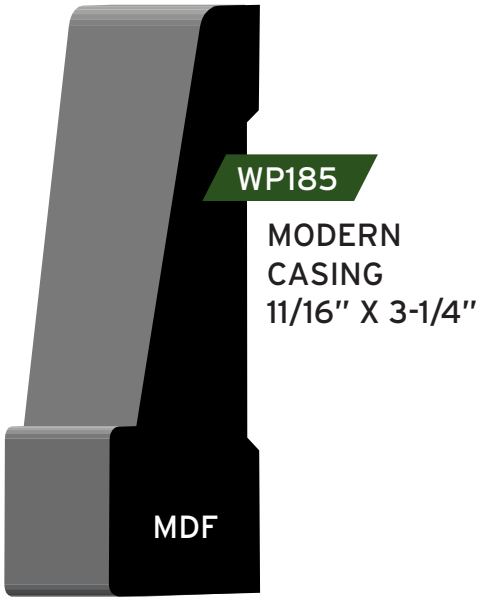

Moulding dimensions subject to change without notice, contact your local WestPac office for correct dimensions

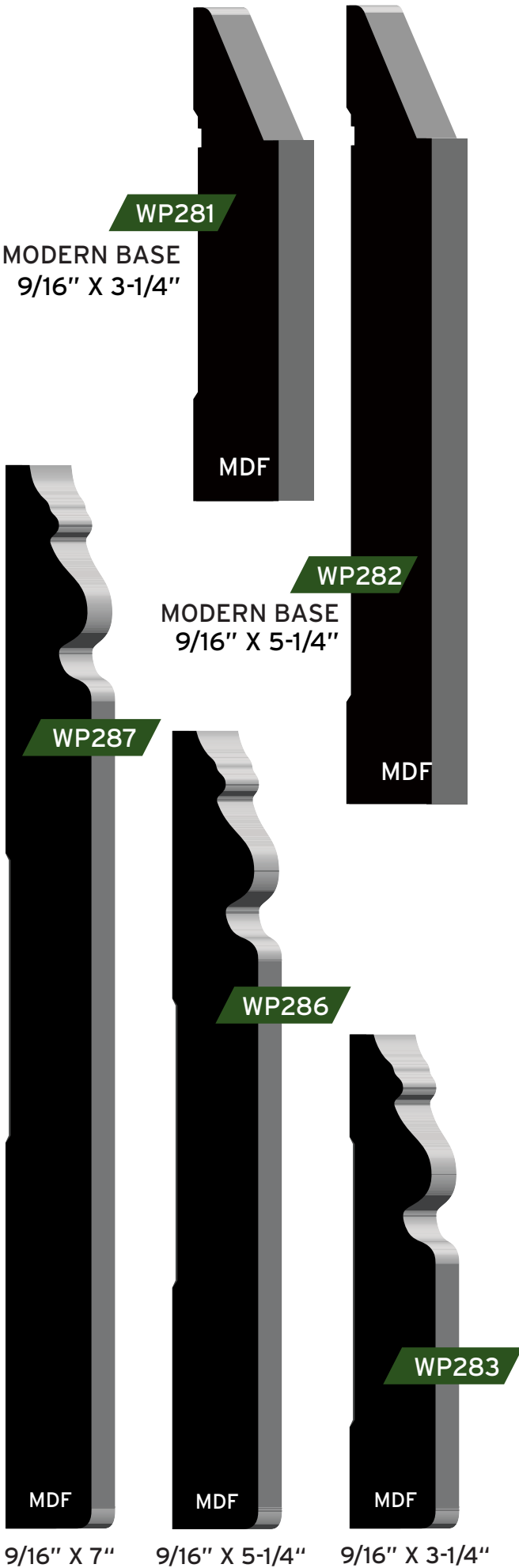

9/16" X 7"

9/16" X 5-1/4"

9/16" X 3-1/4"

Moulding dimensions subject to change without notice, contact your local WestPac office for correct dimensions

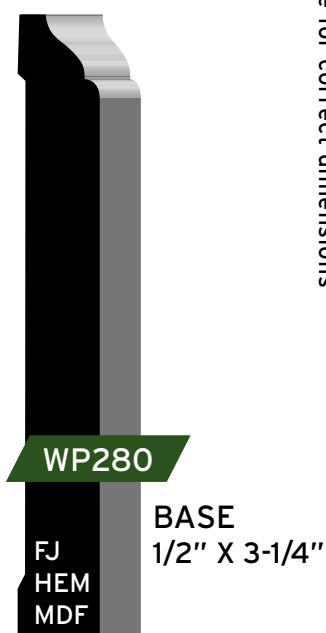
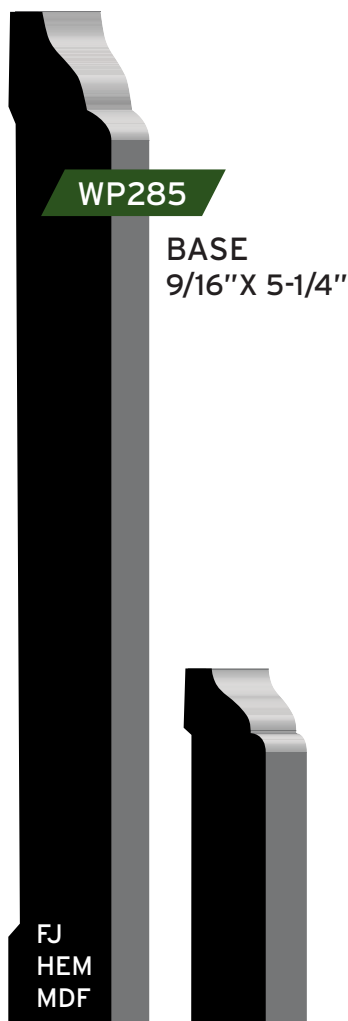

Moulding dimensions subject to change without notice, contact your local WestPac office for correct dimensions

WP275

BASE
7/16" X 3-1/4"

MDF
KA
HEM

WP274

BASE
Economy
3/8" X 3-1/4"

MDF

WP284

BASE
3/8" X 5-1/4"
Economy

WP279

BASE
3/8" X 3-1/4"
Economy

MDF

MDF

Moulding dimensions subject to change without notice, contact your local WestPac office for correct dimensions

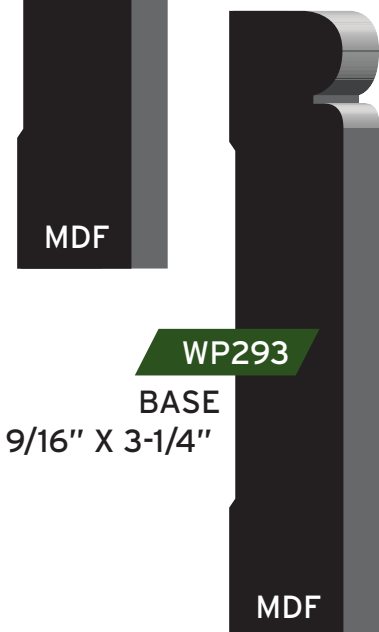

Moulding dimensions subject to change without notice, contact your local WestPac office for correct dimensions



47UL

CROWN
MDF
5/8" X 4-1/4"

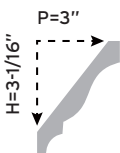

WP313

FJ
KA
TRADITIONAL
CROWN
9/16" X 4-1/4"

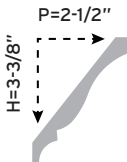

512

MDF

TRADITIONAL
CROWN
5-1/4" X 9/16"

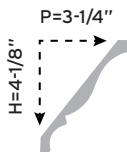

WP312

FJ
MDF

TRADITIONAL
CROWN
HEM
9/16" X 3-1/4"
MDF
9/16" X 3-5/8"

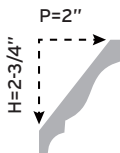

WP354

HEM

TRADITIONAL
CROWN
9/16" X 2-1/4"

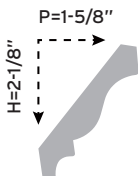

WP368

HEM

TRADITIONAL
CROWN
9/16" X 1-5/8"



Moulding dimensions subject to change without notice, contact your local WestPac office for correct dimensions

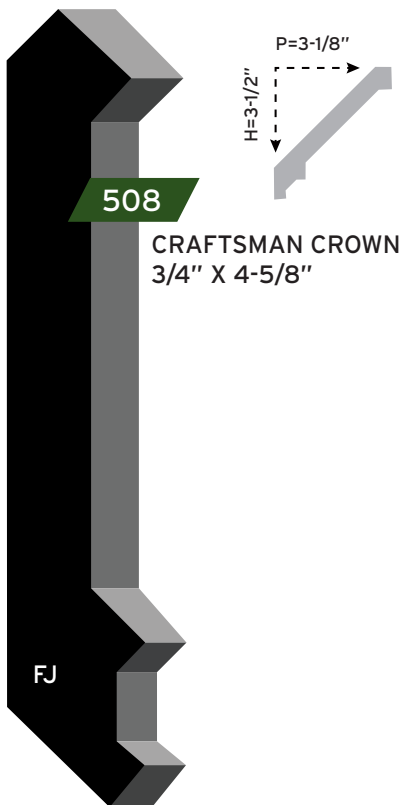

508

CRAFTSMAN CROWN
3/4" X 4-5/8"

FJ



500

HEM

PANEL MOULD
5/8" X 5/8"

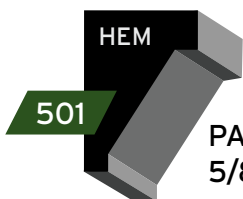

501

HEM

PANEL MOULD
5/8" X 7/8"



504

HEM
FJ

LINTEL
1-1/2" X 2-3/8"



WP911

HEM
FJ

LINTEL
1-3/16" X 2-1/4"

Moulding dimensions subject to change without notice, contact your local WestPac office for correct dimensions

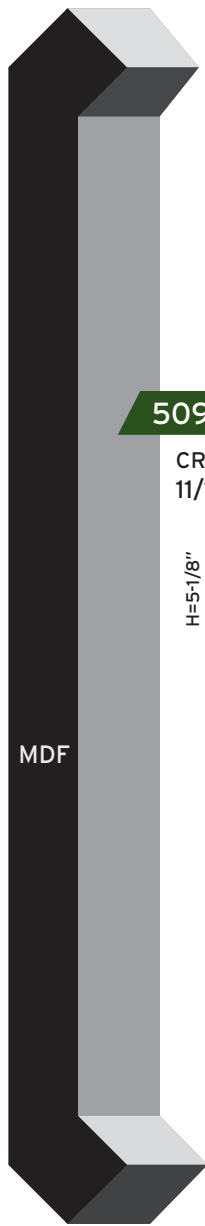

509

CRAFTSMAN CROWN
11/16" X 7-1/2"

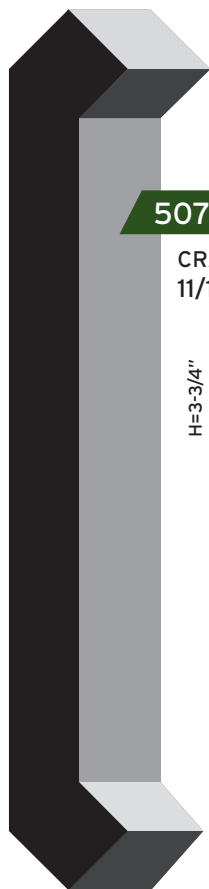
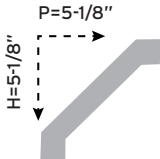

507

CRAFTSMAN CROWN
11/16" X 5-1/4"

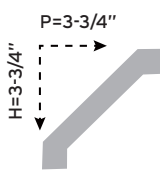

HEM
FJ
MDF

506

CRAFTSMAN CROWN
11/16" X 3-1/4"

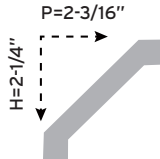

Moulding dimensions subject to change without notice, contact your local WestPac office for correct dimensions

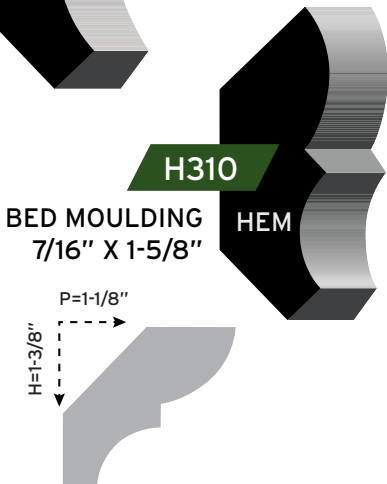
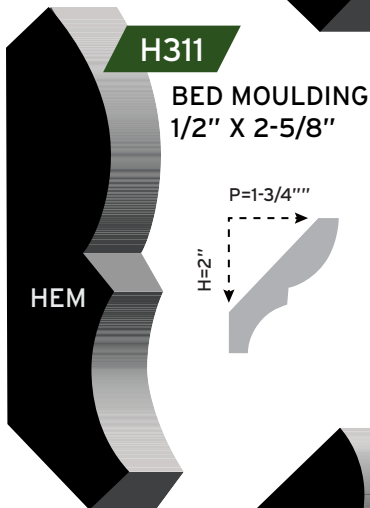
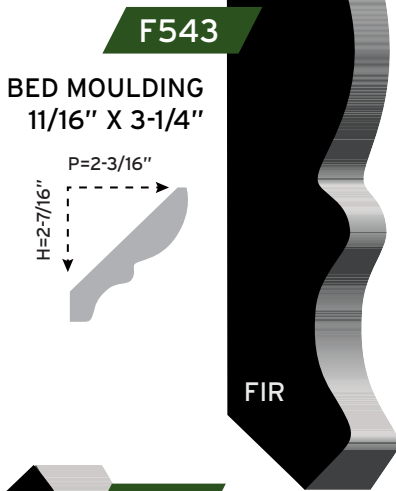
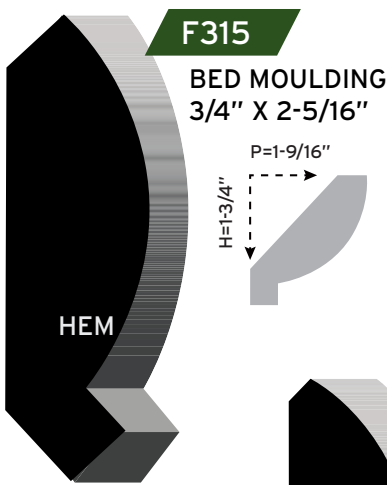

Moulding dimensions subject to change without notice, contact your local WestPac office for correct dimensions

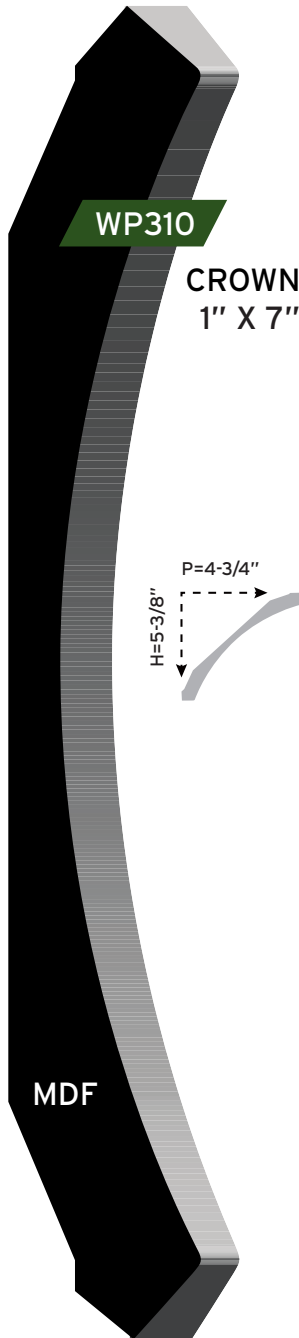
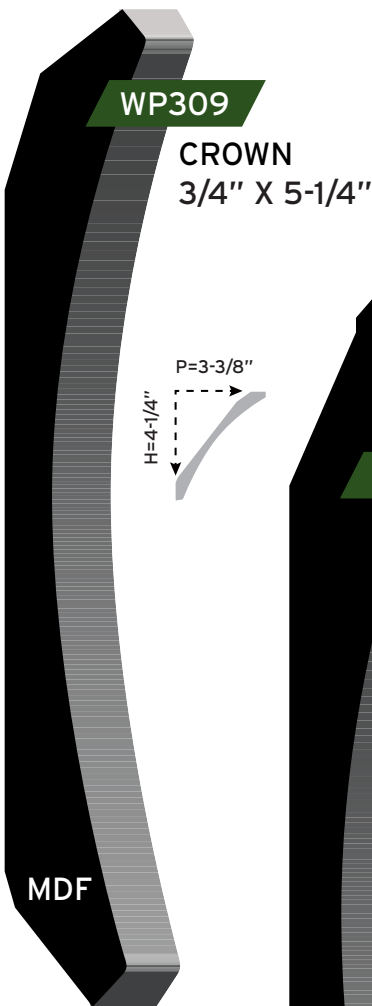

Moulding dimensions subject to change without notice, contact your local WestPac office for correct dimensions



MDF

WP341

CROWN
1-3/16" X 6-5/16"

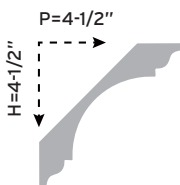

MDF
ALD

WP350

CROWN
5/8" X 5-3/16"

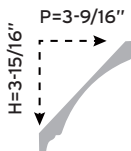

MDF

WP353

CROWN
9/16" X 3-1/2"

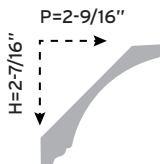

Moulding dimensions subject to change without notice, contact your local WestPac office for correct dimensions

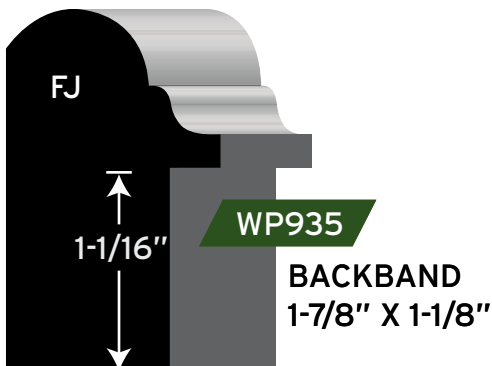
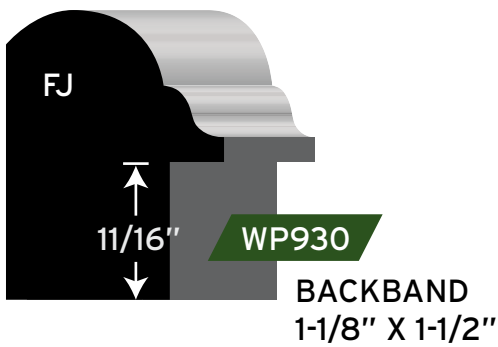
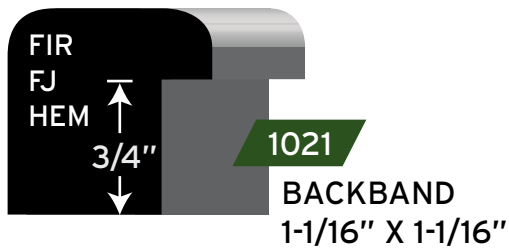
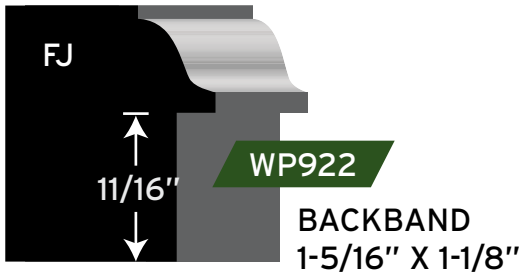

Moulding dimensions subject to change without notice, contact your local WestPac office for correct dimensions



WP1000

CHAIR RAIL
11/16" X 2-5/8"

FJ



WP1004

CHAIR RAIL
9/16" X 2-1/2"

HEM

WP752



POP

CHAIR RAIL
1-1/16" X 5-3/8"



WP980

CHAIR RAIL
3/4" X 3-1/4"

POP



WP711

CHAIR RAIL
11/16" X 1-1/2"

FJ
HEM

Moulding dimensions subject to change without notice, contact your local WestPac office for correct dimensions

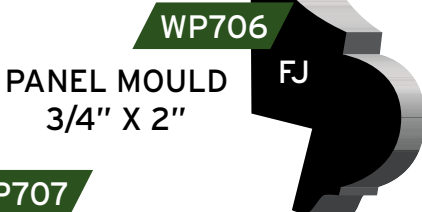
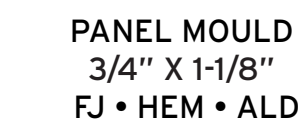
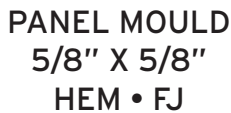
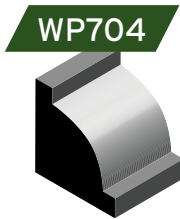
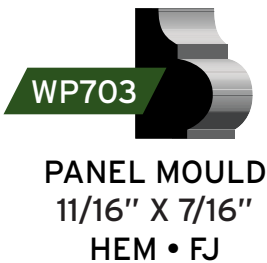
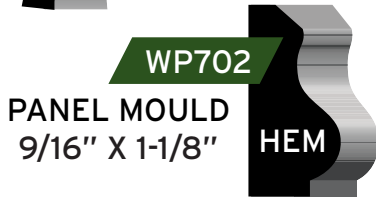
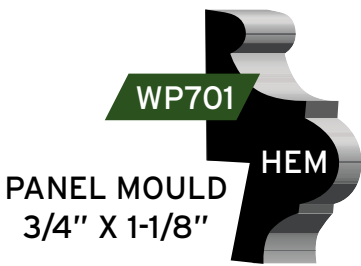

Moulding dimensions subject to change without notice, contact your local WestPac office for correct dimensions

WP953

PARTING BEAD
7/16" X 1-3/8"
HEM • FJ

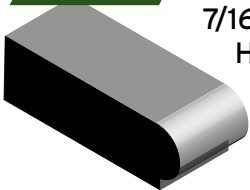

WP301

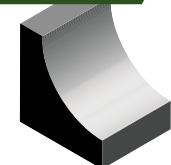

COVE
3/4" X 3/4"
HEM

503



1/2" X 1-1/8"
FJ

WP300

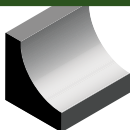

COVE
1/2" X 1/2"
HEM

WP322

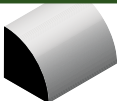

QUARTER ROUND
1/2" X 1/2"
HEM

WP321



3/8" X 3/8"
QUARTER ROUND
HEM

WP451

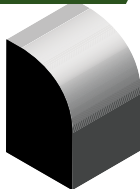

BASE SHOE
7/16" X 11/16"
FJ • HEM • ALD • OAK

WP324

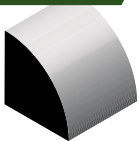

QUARTER ROUND
3/4" X 3/4"
HEM

3/4 SQUARE

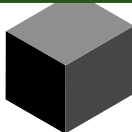

3/4" X 3/4"
FJ347
FJ (7' Specified)

500

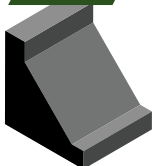

PANEL MOULD
5/8" X 5/8"
HEM

H34
HEM (Random Lengths)

Moulding dimensions subject to change without notice, contact your local WestPac office for correct dimensions

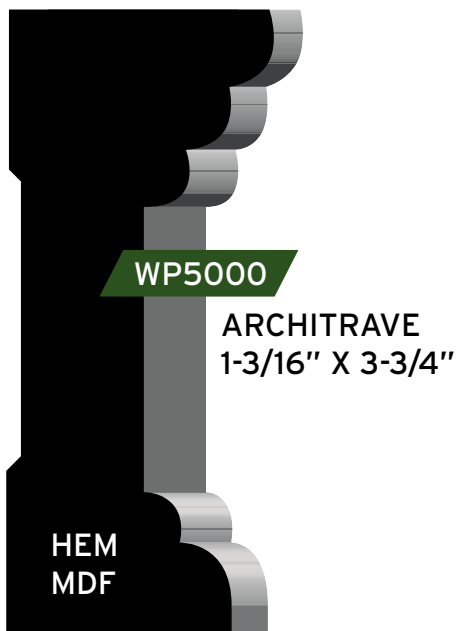
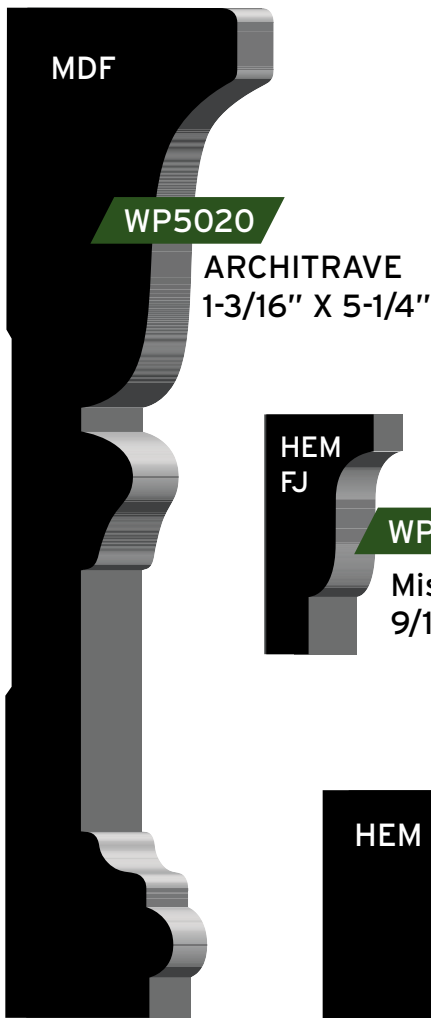

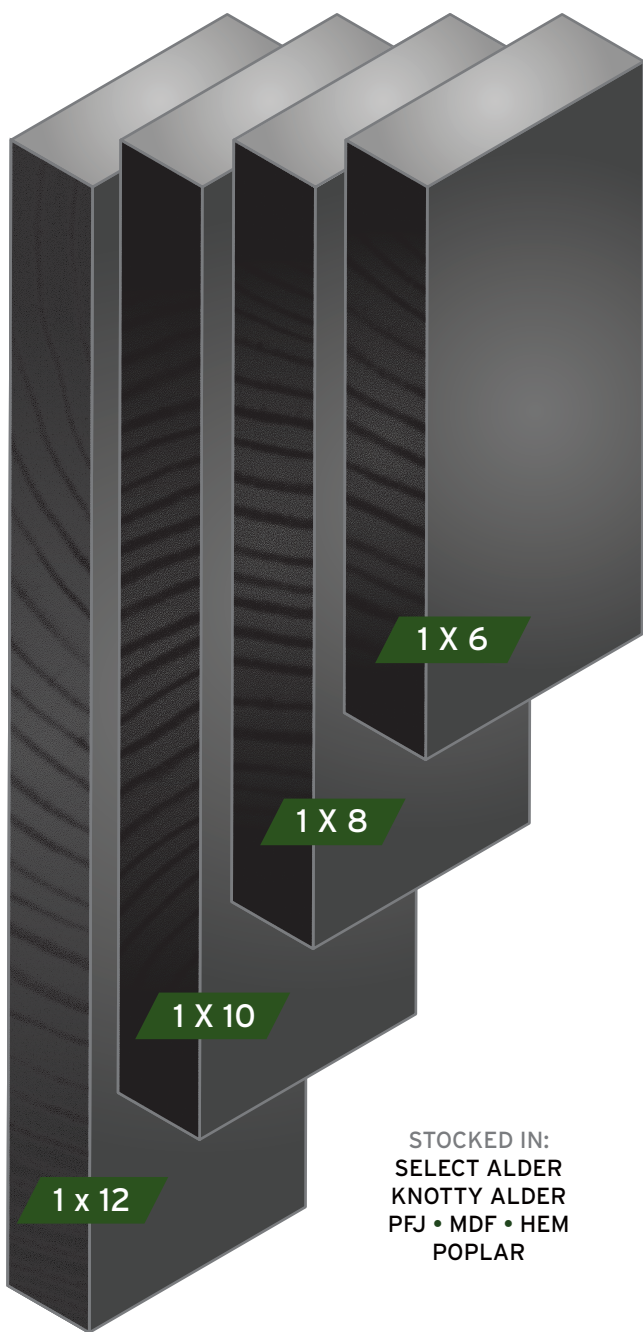

STOCKED IN:
SELECT ALDER
KNOTTY ALDER
PFJ • MDF • HEM
POPLAR

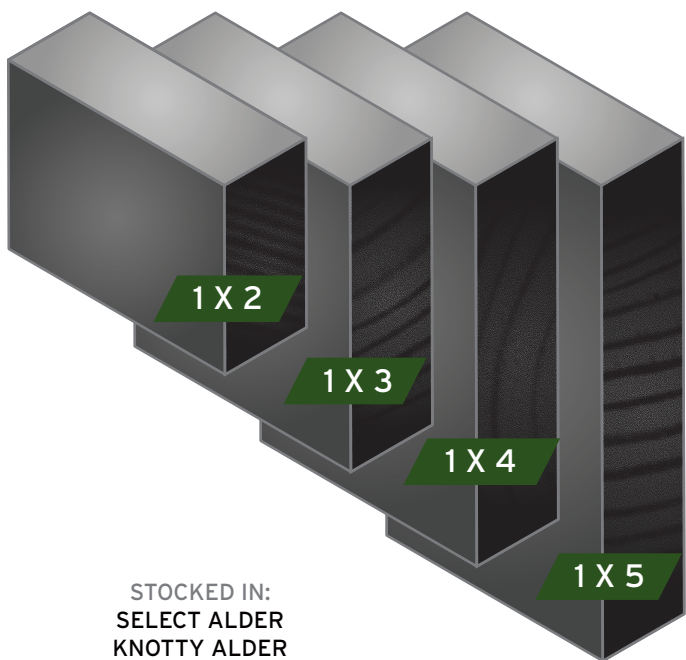

STOCKED IN:
 SELECT ALDER
 KNOTTY ALDER
 PFJ • MDF • HEM

AVAILABLE IN:
 FIR • OAK • POPLAR
 MAPLE • CHERRY

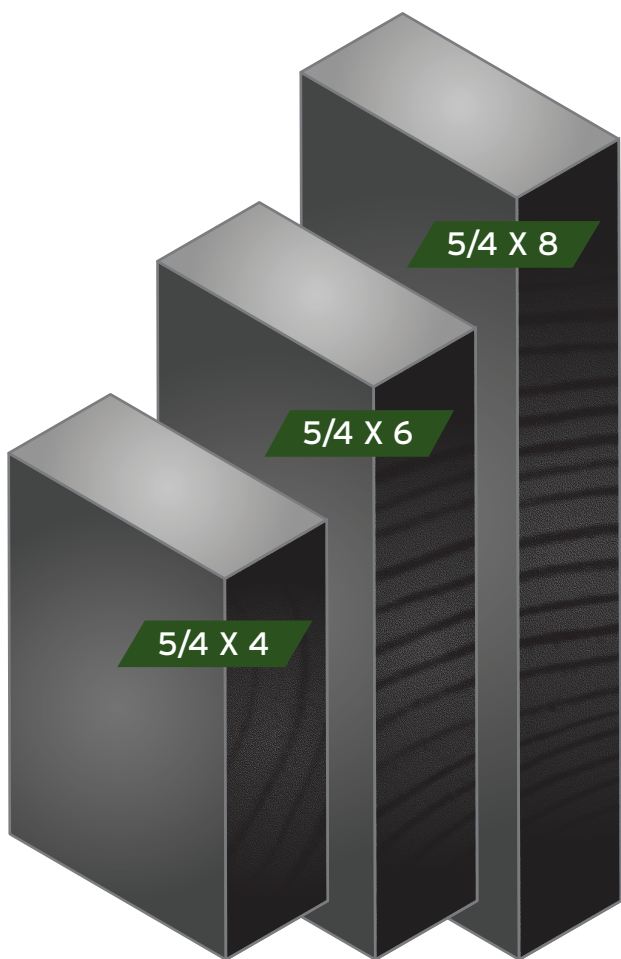

STOCKED IN:
 SELECT ALDER
 KNOTTY ALDER
 PFJ • MDF • HEM

AVAILABLE IN:
 FIR • OAK • POPLAR
 MAPLE • CHERRY

MOULDING

FLAT STOCK

INTERIOR DOORS

STAIR PARTS

HARDWARE

TECHNICAL INFORMATION

NOTES

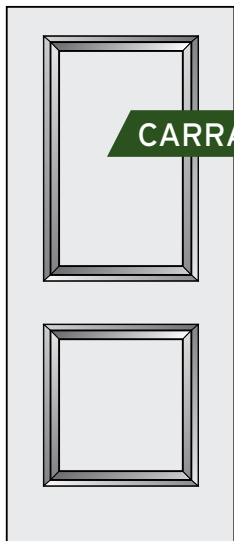
**CARRARA**

SMOOTH
PASSAGE/BIFOLD
6/8 • 8/0

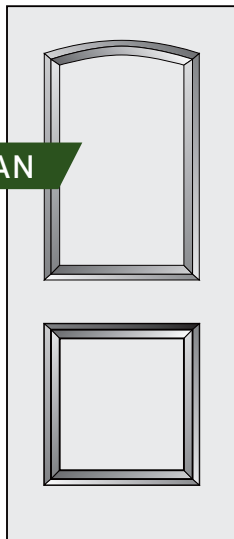
**CAIMAN**

SMOOTH
PASSAGE/BIFOLD
6/8 • 8/0

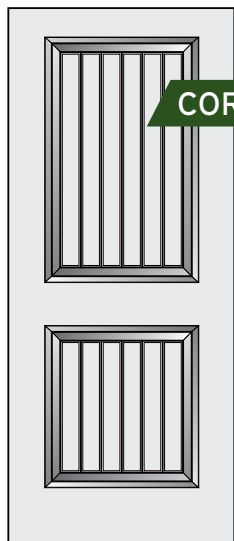
**CORVADO**

SMOOTH
PASSAGE/BIFOLD
6/8 • 8/0

**ROCKPORT**

SMOOTH
PASSAGE/BIFOLD
6/8 • 8/0

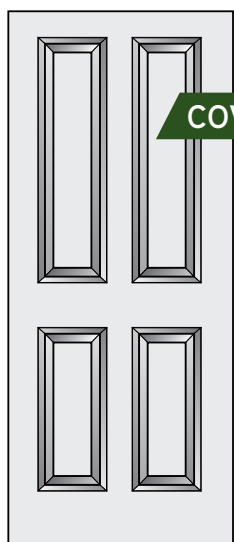
**COVENTRY**

SMOOTH
PASSAGE/BIFOLD
6/8 • 8/0

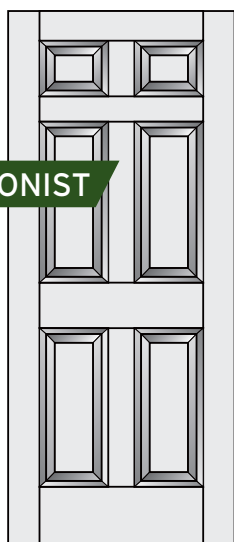
**COLONIST**

SMOOTH or
TEXTURED
PASSAGE/BIFOLD
6/8 • 8/0

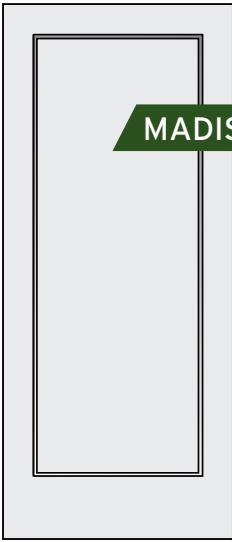

MADISON

FLAT PANEL
SMOOTH
PASSAGE/BIFOLD
6/8 • 8/0

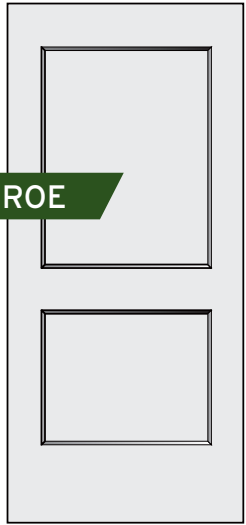

MONROE

FLAT PANEL
SMOOTH
PASSAGE/BIFOLD
6/8 ONLY

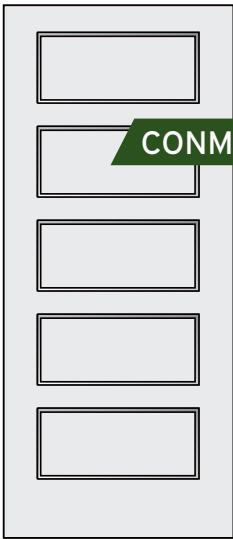

CONMORE

FLAT PANEL
SMOOTH
PASSAGE/BIFOLD
6/8 ONLY



CRAFTSMAN

FLAT PANEL
SMOOTH
PASSAGE/BIFOLD
6/8 ONLY

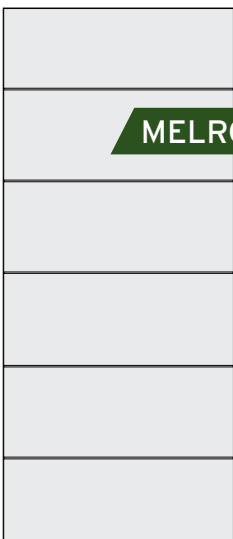

MELROSE

SMOOTH
PASSAGE/BIFOLD
FLUSH W/KERF LINES
6/8 • 7/0

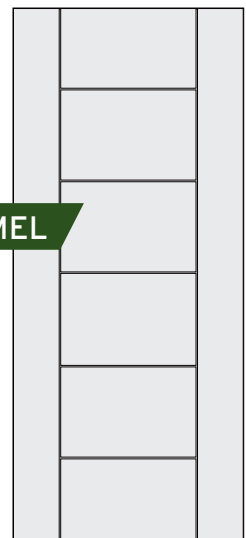

HAMEL

SMOOTH
PASSAGE/BIFOLD
FLUSH W/KERF LINES
6/8 • 7/0

MOULDING

FLAT STOCK

INTERIOR DOORS

STAIR PARTS

HARDWARE

TECHNICAL INFORMATION

NOTES

WESTPAC CASCADE DOORS

SHAKER/SQUARE STICKING • FLAT PANEL
1-3/8" • STILE & RAIL • 6/8 & 8/0
(1-3/4" AVAILABLE IN 2/8 AND 3/0 WIDTHS)

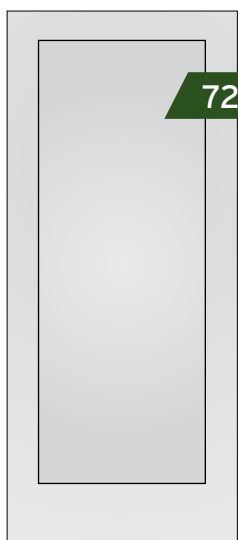

720

PRIMED
HEMLOCK

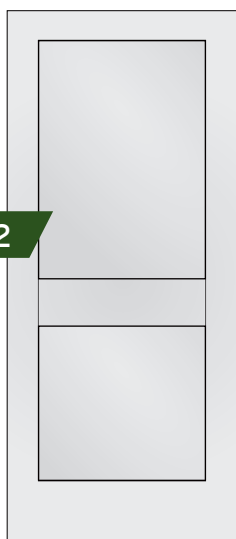

782

PRIMED
HEMLOCK

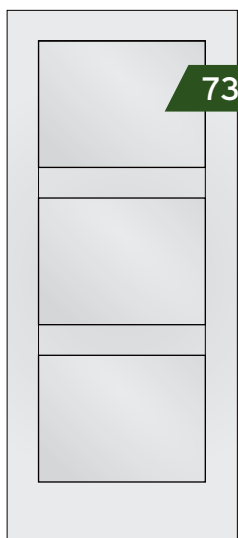

730

PRIMED
HEMLOCK

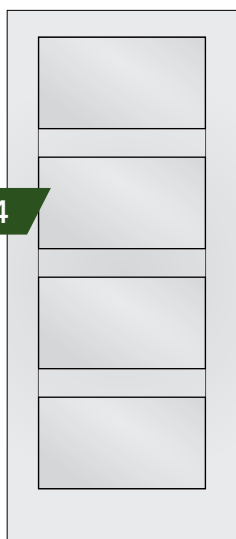

784

PRIMED
HEMLOCK

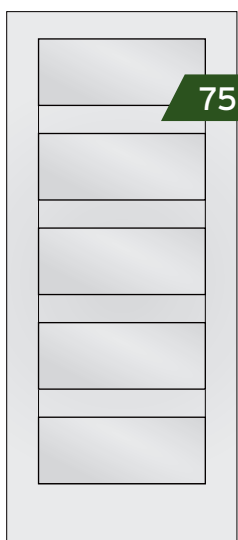

755

PRIMED
HEMLOCK

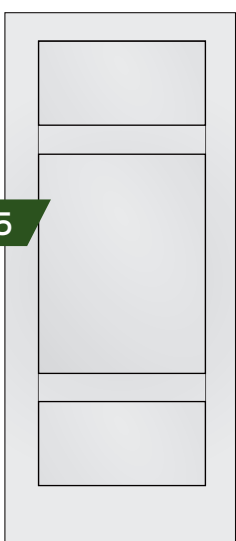

785

PRIMED
HEMLOCK

MOULDING

FLAT STOCK

INTERIOR DOORS

STAIR PARTS

HARDWARE

TECHNICAL INFORMATION

NOTES

WESTPAC CASCADE DOORS

SHAKER/SQUARE STICKING • FLAT PANEL

1-3/8" • STILE & RAIL • 6/8 & 8/0

(1-3/4" AVAILABLE IN 2/8 AND 3/0 WIDTHS)

MOULDING

FLAT STOCK

INTERIOR DOORS

STAIR PARTS

HARDWARE

TECHNICAL INFORMATION

NOTES

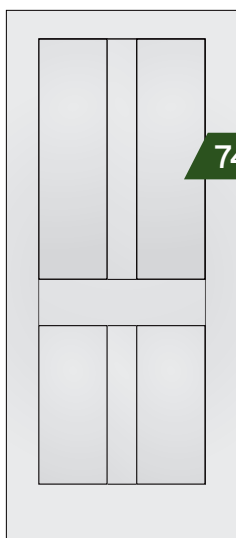

744

PRIMED
HEMLOCK



764

PRIMED
HEMLOCK

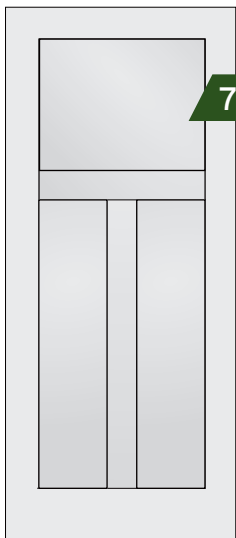

760

PRIMED
HEMLOCK

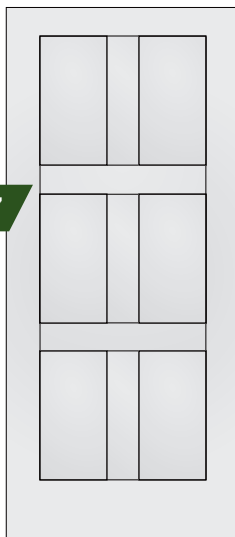

767

PRIMED
HEMLOCK

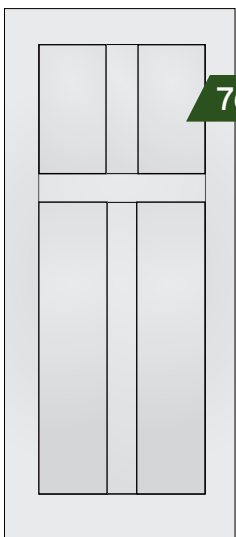

762

PRIMED
HEMLOCK

HANDRAILS

MOULDING

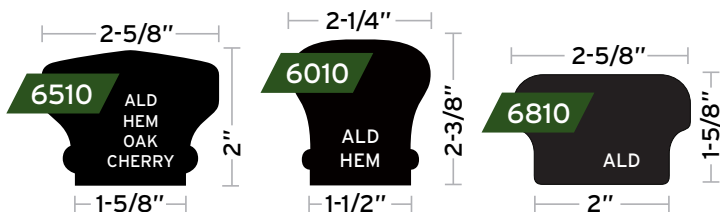

Handrails can be plowed upon request

FLAT STOCK

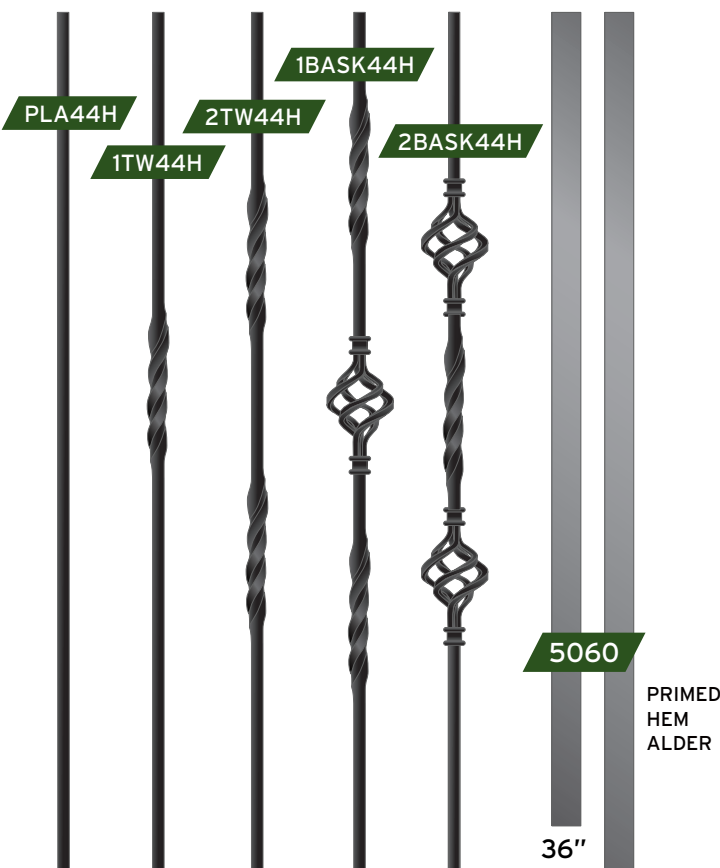

INTERIOR DOORS

STAIR PARTS

HARDWARE

TECHNICAL INFORMATION

SATIN BLACK 1/2" HOLLOW IRON BALUSTERS

44" 44" 44" 44" 44" 1-1/4" X 36" 1-1/4" X 42"

NOTES

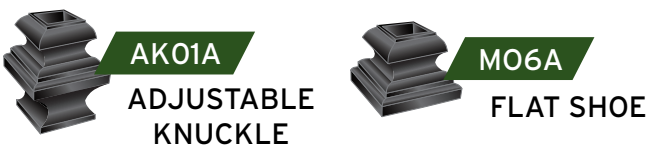

4001CH

CHAMFERED
TOP BLANK
NEWEL
3-1/2" X 56"



HEM
PRIMED
ALD
CHERRY

3-1/2"

5"

1-1/2"
3/4"

6"

3-1/2"

4-3/4"

3-1/2"

56"

23-1/8"

4191

SMALL BOX
NEWEL

HEM
ALD
PRIMED

4-1/2"

4-3/4"

1-3/8"

1-11/16"

1-1/2"

6-1/4"

2-1/8"

18"

2-5/8"

23"

4091FP

FLAT PANEL
BOX NEWEL

HEM
ALD
PRIMED
MAHOGANY

6-1/4"

53-1/2"

EZM

EZ BOX NEWEL
MOUNTING SYSTEM



SATIN NICKEL
DARK BRONZE

S3027

HEAVY DUTY
HANDRAIL BRACKET



SATIN NICKEL
DARK BRONZE

C3002

STANDARD DUTY
HANDRAIL BRACKET

6042

WALL
RAIL

2-1/4"



1-1/4"

ALD
HEM
FJ

6050

FILLET
ALD • HEM

1-1/4"



25/64"

6045

SHOE RAIL
ALD • HEM



3/4"

2-1/2"

BARN DOOR HARDWARE

SLIDING DOOR HARDWARE SETS

BTB6

RUSTIC - OIL RUBBED BRONZE



BTBA

TRACK JOINT ADAPTER

BTS6

MODERN - STAINLESS STEEL

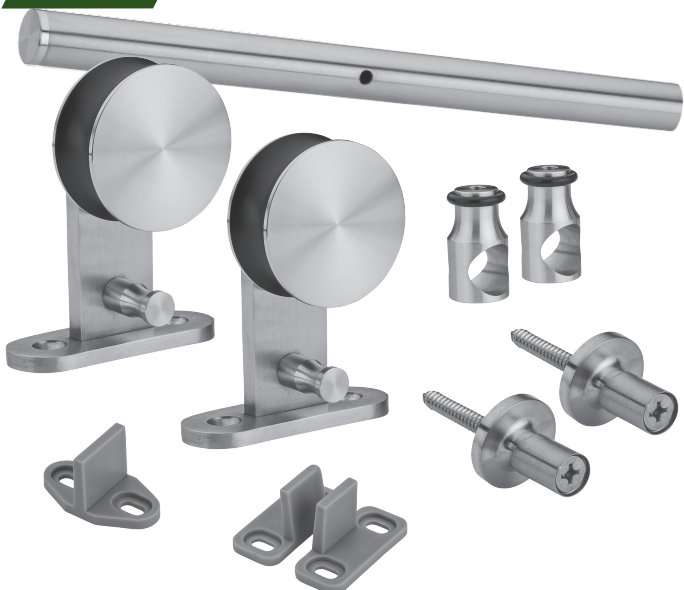

BTSA

TRACK JOINT ADAPTER

MOULDING

FLAT STOCK

INTERIOR DOORS

STAIR PARTS

HARDWARE

TECHNICAL INFORMATION

NOTES

SLIDING DOOR PULLS

MOULDING

FLAT STOCK

INTERIOR DOORS

STAIR PARTS

HARDWARE

TECHNICAL INFORMATION

NOTES

RBP

12" ROUND BAR PULL (RBP)
7/8" DIAMETER
2" PROJECTION

- US15
- US10B
- US26



EP

EDGE PULL (EP)
DIMENSIONS: 3/4" X 4"

- US15
- US10B
- US26

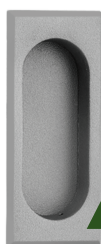

FP

RECTANGULAR FLUSH PULL (FPS)
DIMENSIONS: 1-3/4" X 4"
3/8" DEPTH

- US15
- US10B
- US26



MOULDING

FLAT STOCK

INTERIOR DOORS

STAIR PARTS

HARDWARE

TECHNICAL INFORMATION

NOTES



SEATTLE
HANDLESET

Kwikset

TRADITIONAL HARDWARE



HAWTHORNE
HANDLESET



CHELSEA
HANDLESET



HANCOCK
KNOB



POLO
KNOB



TUSTIN
LEVER



780
DEADBOLT

CONTEMPORARY HARDWARE



DOWNTOWN 258S
DEADBOLT



TAVARIS
HANDLESET



UPTOWN 258R
DEADBOLT



HALIFAX
LEVER

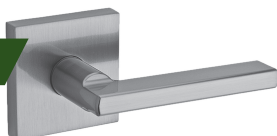

SYDNEY
LEVER

MILAN
LEVER



MONTREAL
LEVER

KATARA



LEVER

RESIDENTIAL HARDWARE

COLONIAL
KNOB



BALL
KNOB



WAVE
LEVER



SINGLE CYLINDER
DEADBOLT



MOULDING

FLAT STOCK

INTERIOR DOORS

STAIR PARTS

HARDWARE

TECHNICAL INFORMATION

NOTES

FINISH LUMBER DESCRIPTIONS

3/4" thick with four square edges, and available in random lengths.

Custom Milling Available in all species:

- Sanding
- Ripping to Custom Width
- Planing to Custom Thickness

RED OAK

Sapwood is white to light brown and the heartwood is a pink or reddish brown. Similar in appearance to White Oak, but with smaller grain rays. Red Oak is mostly straight-grained, with a coarse texture.

WHITE OAK

The sapwood is light-colored and the heartwood is light to dark brown. White Oak is mostly straight-grained with a medium to coarse texture, and with longer grain rays than red oak.

EASTERN HARD MAPLE

Creamy white in color with a fine, uniform texture and generally mixed grain.

AMERICAN CHERRY

Rich red to reddish brown. Will darken with age and on exposure to light. May contain some creamy white sapwood. Fine uniform, straight grain, satiny, smooth texture.

CLEAR ALDER

Light brown with a yellow or reddish tinge. Fairly straight-grained with a uniform texture. Occasional pin knots may be present.

KNOTTY ALDER

Light brown with a yellow or reddish tinge. Fairly straight-grained with a uniform texture. Multiple large open and tight knots will be present.

CVG FIR

Even, straight, vertical grain that stains out beautifully. Reddish in color. Also good for outdoors when painted.

CVG HEMLOCK

Our most popular stain grade softwood. A close relative of Fir but more yellowish in color. Fine uniform texture and vertical grain pattern, that easily obtains a rich finish. Also good for paint grade.

EASTERN POPLAR

Solid paint grade hardwood. Smooth and even surface that paints out beautifully. Our high quality Eastern Poplar is lighter in color, more dense, and less fuzzy when machining than Western varieties.

WALNUT

Light to dark chocolate brown in color, with straight grain from the trunk and more waved grain near the roots. Walnut is hard and durable with excellent shaping qualities, making it one of the most popular and versatile woodworking species. It takes finish very well.

STAINING INSTRUCTIONS

RECOMMENDED WOOD STAINING PROCEDURE

WOOD PREPARATION

Wood must be dry and cleaned of dirt, grease, wax, polish, and marks. See STEP 1 for details.

(For exterior wood doors, Western Pacific recommends Epifanes Wood Finish Matte top coat for the best results and long lasting finish. (Available at Marine Supply. Epifanes.com))

THE "FINGERNAIL TEST"

Determine if you have a soft wood or a hard wood.

We consider Fir, Hemlock and Alder to be softwoods and Oak, Cherry and Maple are typically hardwoods. If your fingernail dents the surface when you scratch it, you have a soft wood.

Since soft woods tend to absorb stain unevenly and become blotchy easily, pre-treat the wood using pre-stain wood conditioner before staining. This critical extra step will help you control stain color penetration and prevent blotchiness.

CHOOSING A COLOR

Your finished color is determined by many factors, from the color of the stain selected to how long the stain is left on.

But remember: Different species of wood absorb stain differently. Test the color on an inconspicuous area or sample board before you start staining the most visible parts of your project.

Always stop your staining process if you are not achieving your desired finish and ask a painting professional for additional advice.

To assure the highest quality results when applying interior wood stain, follow these steps:

STEP 1: Start with a medium grade of sandpaper (e.g., 120-grit) and gradually work your way to a finer grade (e.g., 220-grit).

Sand in the direction of the grain for a smooth uniform finish, and remove all sanding dust (using a vacuum, dry paint brush or tack cloth) before finishing.

STEP 2: Mix the stain thoroughly before you begin and frequently while you're staining. This helps keep the color consistent throughout the project. Ingredients in stains and finishes can settle over time. Stir until all settlement is evenly dispersed. Shaking will only add unwanted bubbles to the product.

STEP 3: Before proceeding, apply the stain on a discreet area of wood to test the color.

TIP: ●●●

Apply stain only at the proper temperature. For most stains, 70°F is the optimum, with the safety range from 50° to 90°F.

Stains do vary, so check the label first. Avoid high humidity when applying stain. All finishes, including stains and paint, have trouble drying in moist conditions.

STEP 4: Apply stain by brushing or wiping it in the direction of the grain, using smooth, even strokes. Wipe off any excess.

TIP: ●●●

Avoid unattractive lap marks by applying stain from an unpainted area back into the last wet stain. In other words, don't let a section of stain dry before you blend it in with stain from an adjoining section.

STEP 5: Let dry completely (usually 24 hours).

Apply a second coat of stain if you want a darker look.

STEP 6: After the wood is dry, brush or spray on a uniform coat of your top coat product. After the top coat dries, lightly sand the trim using 220-grit sandpaper to eliminate brush strokes or paint drips. Use a damp sponge or tack cloth to remove all sanding dust. Recoat your top coat and follow the sanding procedure until your desired finish is achieved.

PAINTING INSTRUCTIONS

RECOMMENDED PROCEDURE TO PAINT WOOD AND MDF MOULDINGS AND BOARDS

MOULDING

FLAT STOCK

INTERIOR DOORS

STAIR PARTS

HARDWARE

TECHNICAL INFORMATION

NOTES

PART 1 • PREPARE THE TRIM

STEP 1: Use a damp sponge to clean dirt and grime from trim. If needed, use the rough side of a sponge to ensure a clean starting surface.

STEP 2: Sand the surface. After the trim has been sanded, use a damp sponge to wipe away any dust.

SANDING TIP: If the trim is smooth, lightly sand using 120-grit sandpaper until all shine disappears from the trim. If the trim has a rough milling area start by sanding with coarse, 80-grit sandpaper. Then, move to less-coarse sandpaper such as 100 or 120-grit to smooth the surface.

STEP 3: Fill in holes, dents and cracks with a lightweight spackling compound. (Follow directions on the spackling container for best results.) When the spackle dries completely, lightly sand the spackled areas using 120-grit sandpaper to smooth out the surface. Use tack cloth to remove any sanding dust from the trim.

STEP 4: Dust off walls and ceiling around the trim to ensure painter's tape adheres well. Apply painter's tape to walls and ceilings surrounding the trim, being careful not to stick the tape to the trim itself. To prevent paint from bleeding through the tape, try to use one long piece of tape instead of multiple shorter pieces.

STEP 5: After you have applied the tape, press the tape's edges with a clean spackling or putty knife to ensure adhesion, as this helps prevent the paint from bleeding through the edges.

PART 2 • PAINT THE TRIM AND BOARDS

STEP 1: Apply primer to trim, covering any bare wood and spackled areas. Allow primer to dry for 24 hours. After the drying period, if bare wood or spackle is showing, apply another coat of primer to the trim.

STEP 2: After the primer dries, lightly sand the trim using 120-grit sandpaper to eliminate brush strokes or paint drips. Use a damp sponge or tack cloth to remove all sanding dust.

STEP 3: Apply paint to the trim using short, horizontal brush or spray-gun strokes. Repeat the motion until a few feet of trim (not the full length) are covered in paint.

STEP 4: Allow the paint to dry for 24 hours. After the drying period, for latex paint lightly sand the trim using 180-grit sandpaper to eliminate brush strokes or paint drips. Use a sponge or tack cloth to remove all sanding dust. Oil based paint does not require sanding between paint applications. Apply paint to the trim using short, horizontal brush or spray-gun strokes. Repeat the motion until a few feet of trim (not the full length) are covered in paint.

STEP 5: Before paint dries, carefully pull tape off of the wall and trim.

RETURNS

Material returns are subject to Western Pacific approval. Western Pacific will accept a return of a product, for credit, that has been purchased from Western Pacific inventory. Western Pacific will not accept a return of product, for credit, that has been modified or damaged by a person or party other than Western Pacific. Examples of such product are millwork items that have been cut in length, hardware not in its original box, etc.

Furthermore, product ordered for a specific job, such as pre-hung doors, non-stock doors only, pre-finished millwork, etc., may not be returned for credit.

CANCELLATIONS & CHANGES

Once an order has been placed for custom items, pre-hung doors, or windows, the order may not be cancelled or otherwise changed.

WARRANTY

Western Pacific makes no representations or warranties, either expressed or implied, with respect to the building materials beyond those specifically made by the manufacturer. We can help coordinate warranty resolution for products, but it will be your responsibility to contact the manufacturer directly. Western Pacific is not responsible for any type of freight charges for warranty issues and is not responsible for warranty issues or discrepancies for products exported outside the USA.

DELIVERY

Western Pacific will make every effort to deliver all product in a timely manner. However, Western Pacific assumes no liability for theft, or delivery delays, beyond the reasonable control of Western Pacific.

PAYMENT

All charges are due and payable on the 10th of each month, except for cash accounts which are due prior to production. Any disputes must be raised within 10 days. Buyer acknowledges that any quotes or bids from Western Pacific are only for the materials listed and buyer assumes responsibility to ensure quantities are sufficient to complete the job.



LOCATIONS



Denver • Colorado

320 S Lipan Street
Denver, CO 80223
Phone: 303-454-8811
Fax: 303-394-3312



Portland • Oregon

2805 NW 31st Avenue
Portland, Oregon 97210
Phone: 503-223-8818
Fax: 503-224-9129



Bellevue • Washington Design Studio

13208 NE 20th Street • Suite 150
Bellevue, WA 98005
Phone: 425-250-8327
Fax: 425-558-5828



Seattle • Washington

1101 Industry Street
Everett, WA 98203
Phone: 425-366-8828
Fax: 425-742-5280



Bend • Oregon

827 SE Business Way • Suite A
Bend, OR 97702
Phone: 541-322-8818
Fax: 541-382-3125



Medford • Oregon

502 Parsons Drive
Medford, OR 97501
Phone: 541-772-8818
Fax: 541-770-3736



Houston • Texas

7607 Bluff Point Drive
Houston, TX 77086
Phone: 832-975-0070
Fax: 832-975-0071

HOURS
MONDAY - FRIDAY
7 AM - 4:30 PM

gowestpac.com